

Б →

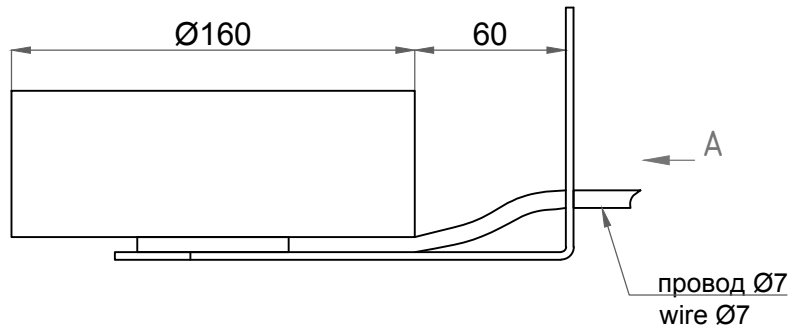

← A

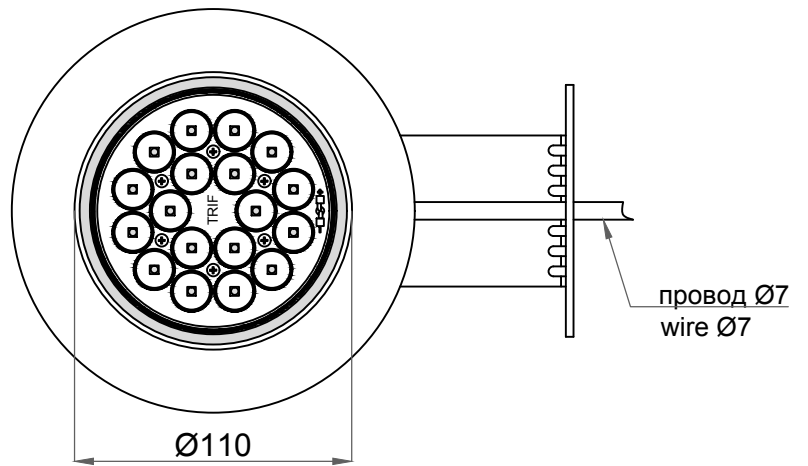

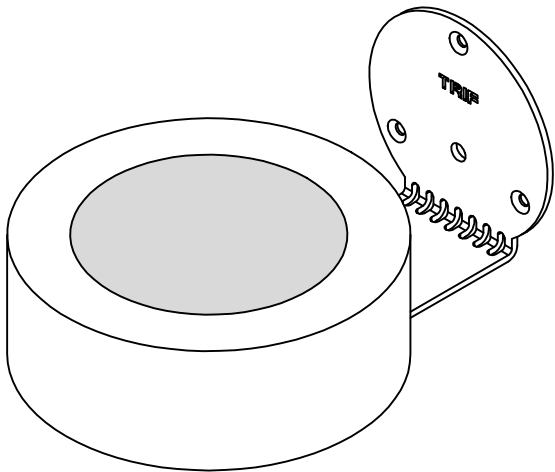
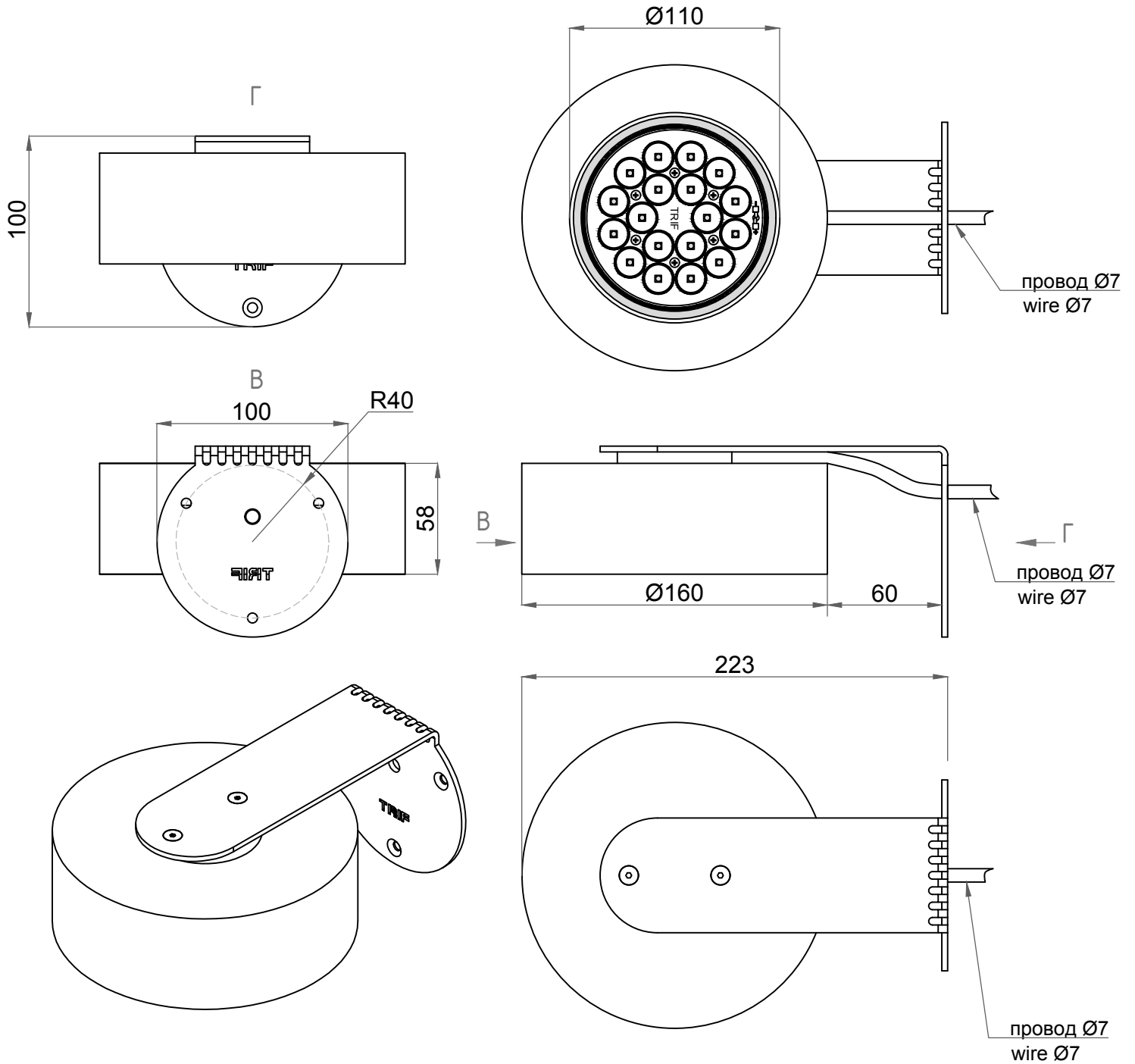

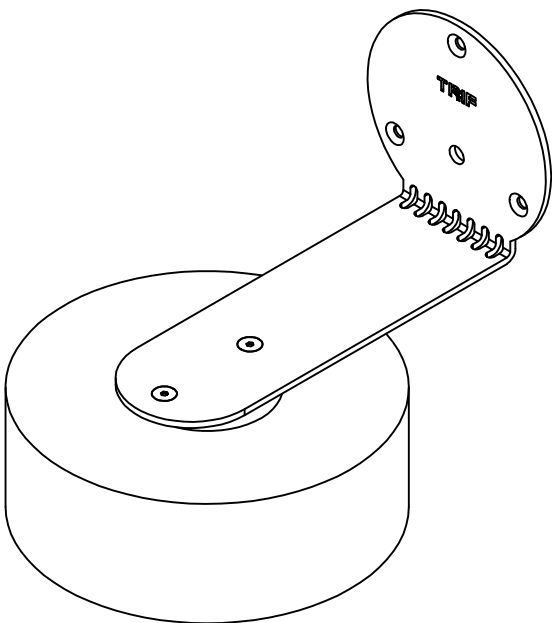
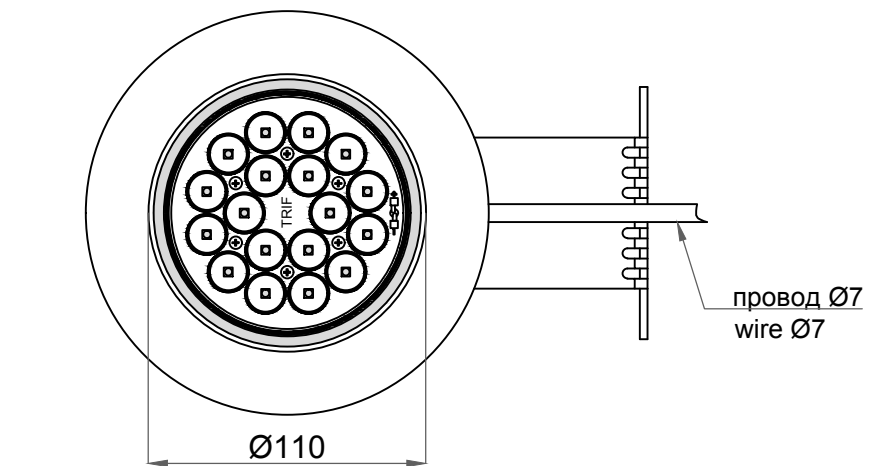
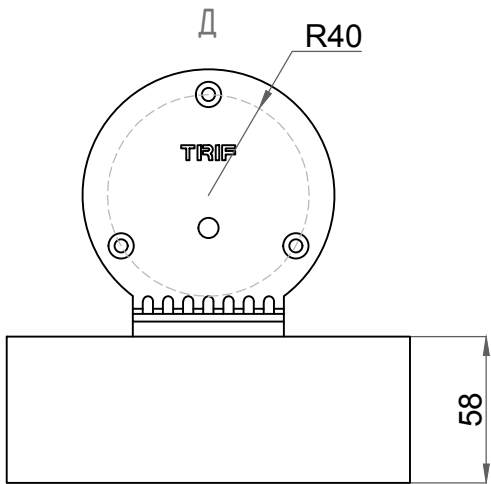
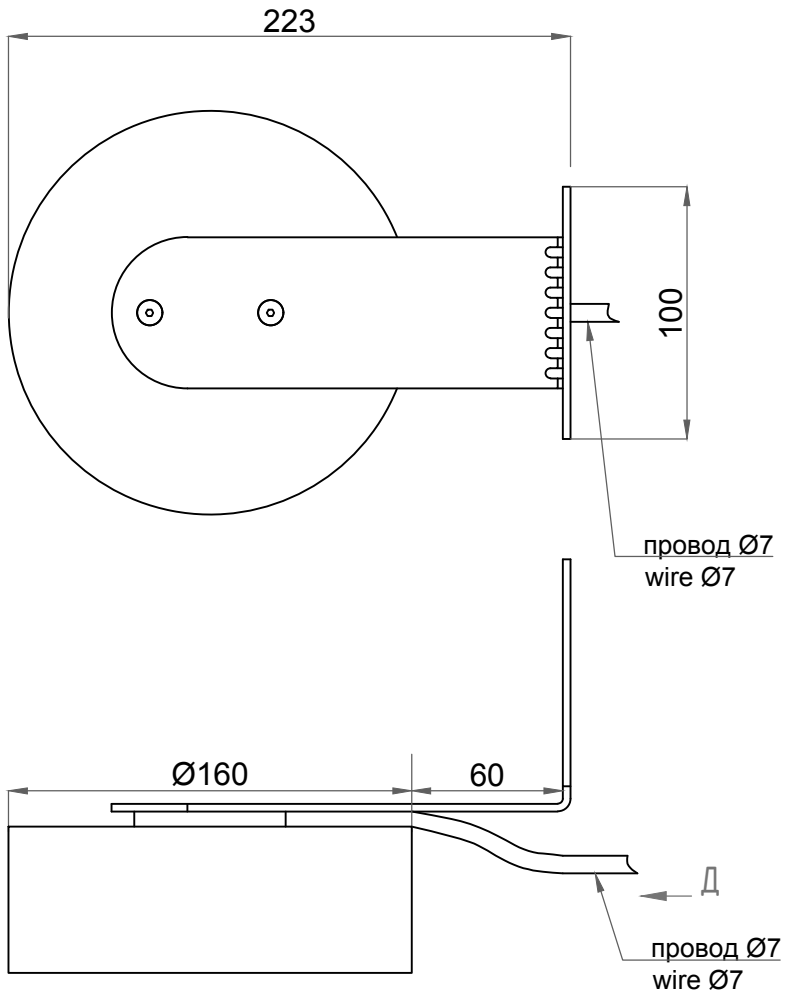
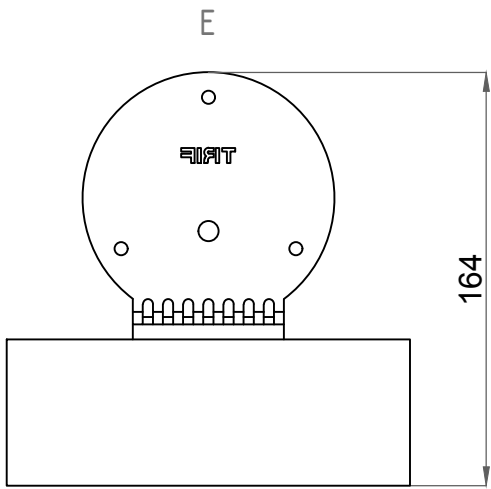

SATURN F

Монтажная схема

TRIF

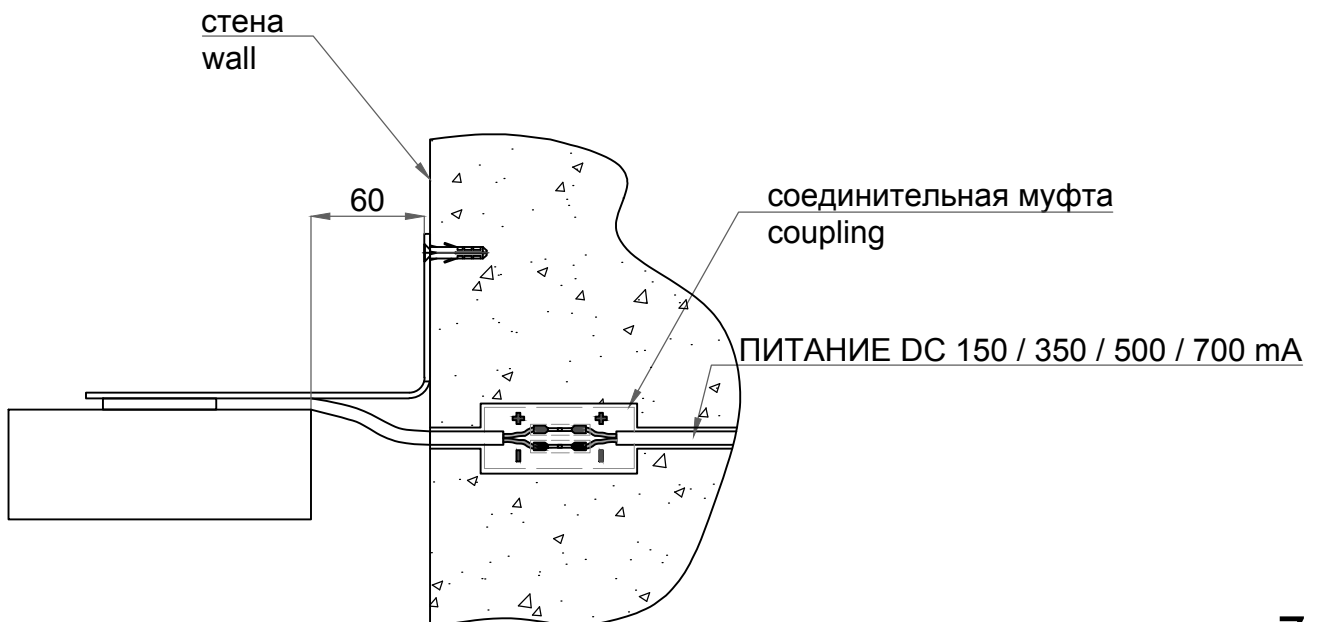
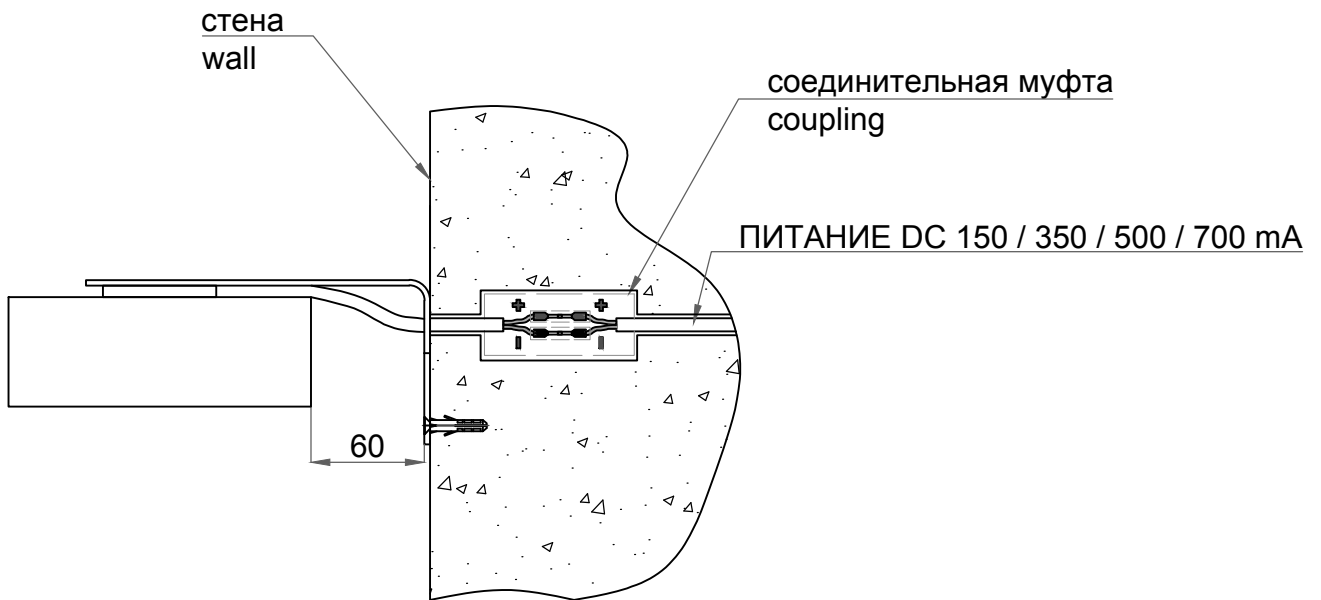
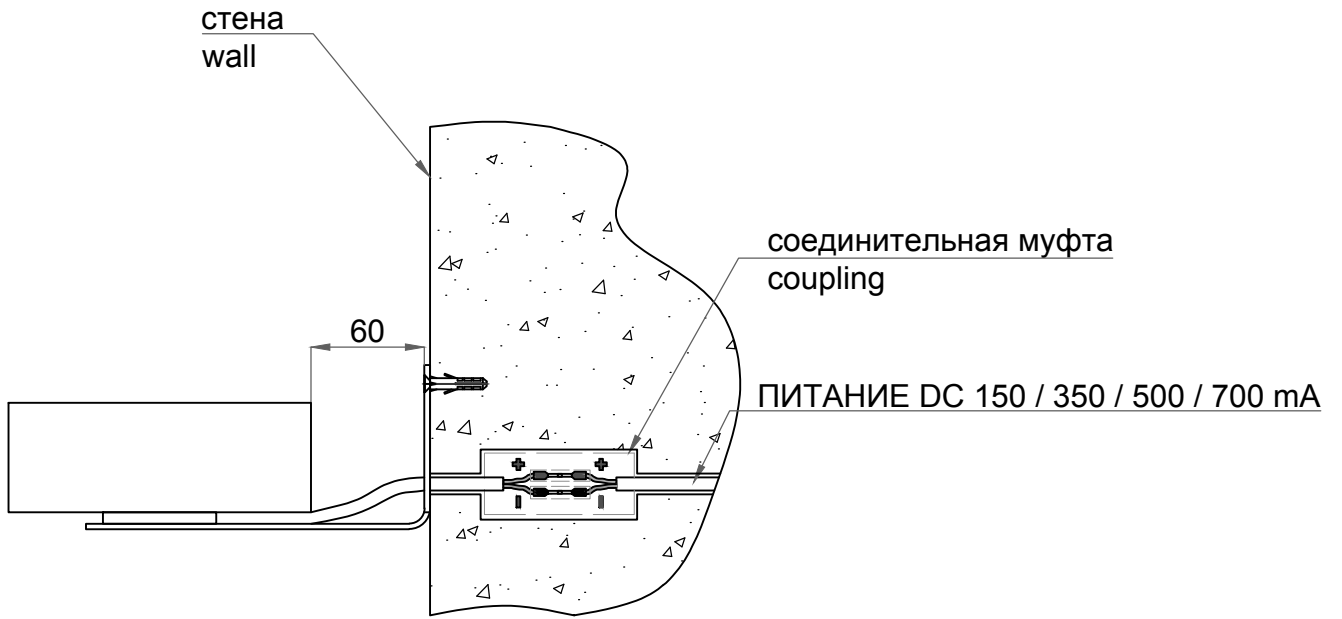

SATURN F

Подключение Electrical connection

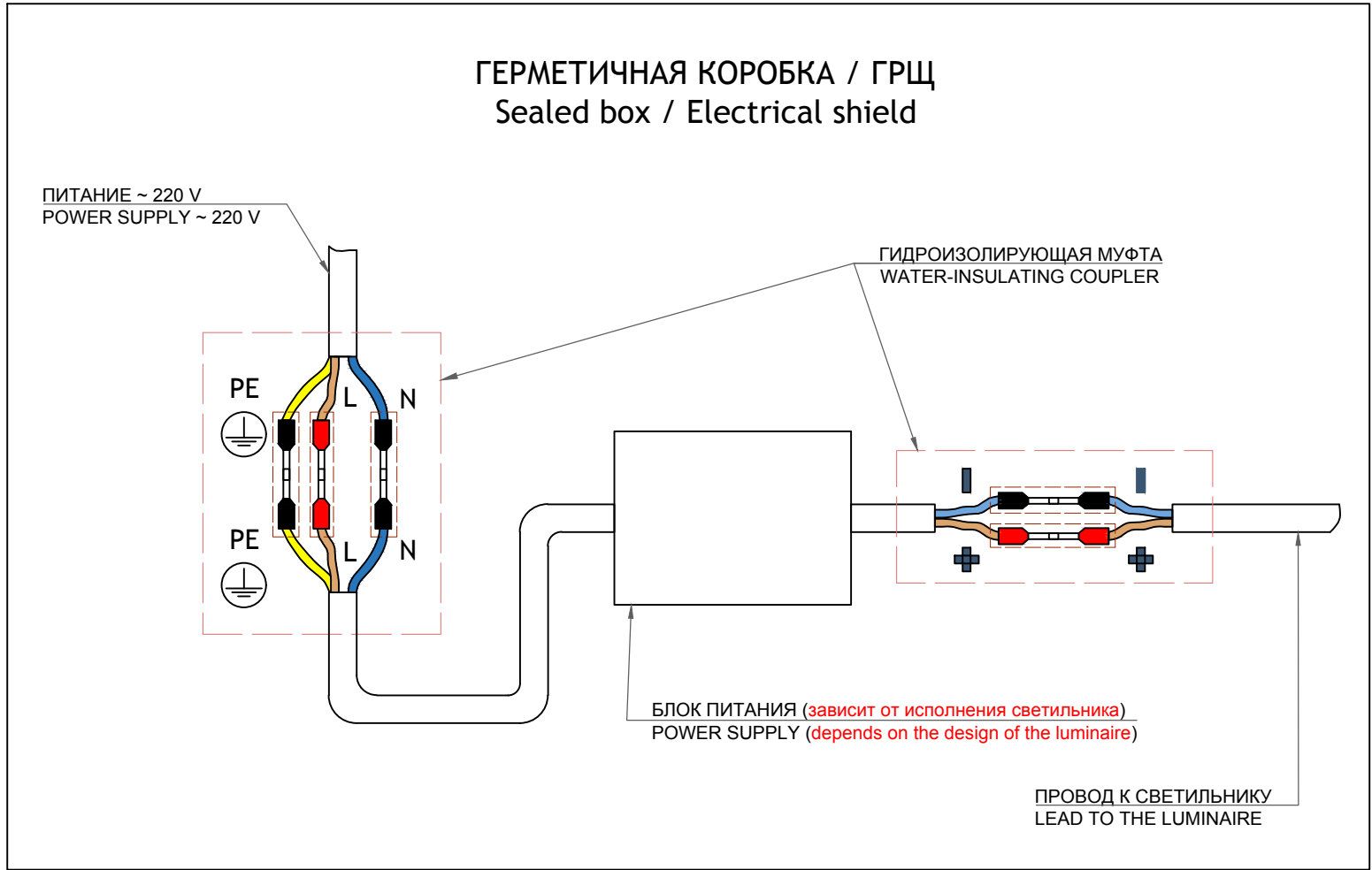
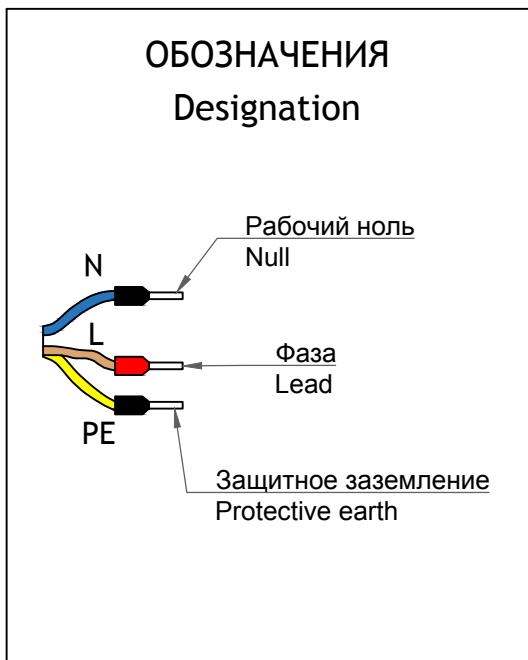

TRIF SATURN F

Технические характеристики настенного светодиодного светильника

Цветовая температура (K)	3000/4000/RGB/RGBW/R/G/B
Световой поток (Лм/Вт)	170
Цветопередача (Ra)	90
Оптика	15°, 25°, 30°, 45°, 60°, 90°
Подключение	Драйвер постоянного тока 150мА (8 Вт), 350 мА (18 Вт), 500 мА (27 Вт), 700 мА (36 Вт)
Степень защиты	IP68
Материал	Анодированный алюминий, сталь и ПЛЕКСИГЛАС

TRIF SATURN F

Specifications of wall LED spotlight

Color temperature (K)	3000/4000/RGB/RGBW/R/G/B
Luminous efficacy (Lm/W)	170
Color Rendering Index (Ra)	90
Optics	15°, 25°, 30°, 45°, 60°, 90°
Connection	DC 150 mA (8 W) 350 mA (18 W) 500 mA (27 W), 700 mA (36 W)
Ingress Protection Rating	IP68
Material	Anodized aluminum, stainless steel and PLEXIGLAS

СХЕМА ЭЛЕКТРИЧЕСКАЯ
ELECTRIC SCHEME

SATURN F

подключение настенного светодиодного светильника
С ИСТОЧНИКОМ ПОСТОЯННОГО ТОКА

SATURN F
connection of a wall LED Light Fixture
With constant current source

